

# ASSEMBLY INSTRUCTIONS

FOR

## DYNALITE PRO SERIES REAR PARKING BRAKE KIT VENTED ROTOR TYPE (2.36 OFFSET)

MOPAR 8-3/4 / DANA 60

FOR USE W/GREEN<sup>(1)</sup> NON-ADJUSTABLE BEARINGS W/SNAP RING

PART NUMBER

**140-7144\***

### WARNING

INSTALLATION OF THIS KIT SHOULD **ONLY** BE PERFORMED BY PERSONS EXPERIENCED IN THE INSTALLATION AND PROPER OPERATION OF DISC BRAKE SYSTEMS. IT IS THE RESPONSIBILITY OF THE PERSON INSTALLING ANY BRAKE COMPONENT OR KIT TO DETERMINE THE SUITABILITY OF THE COMPONENT OR KIT FOR THAT PARTICULAR APPLICATION.



### FOR OFF ROAD USE ONLY

BEFORE OPERATING VEHICLE, TEST THE BRAKES UNDER CONTROLLED CONDITIONS. MAKE SEVERAL STOPS IN A SAFE AREA FROM LOW SPEEDS AND GRADUALLY WORK UP TO RACING SPEEDS. **DO NOT RACE ON UNTESTED BRAKES!** ALWAYS UTILIZE SAFETY RESTRAINT SYSTEMS WHILE OPERATING VEHICLE.

### IMPORTANT

READ DISCLAIMER OF WARRANTY INCLUDED IN THE KIT.

**WARNING: Some cleaners may stain or remove the finish on brake system components. Test the cleaner on a hidden portion of the component before general use.**

\*POLISHED CALIPERS AVAILABLE; ADD "-P" TO END OF PART NO. \*DRILLED ROTORS AVAILABLE; ADD "-D" TO END OF PART NO.  
(1) FOR USE WITH GREEN BEARINGS, P/N MO400.

## Important Notice - Read This First

Before any tear-down or disassembly begins, it is important to verify which bearing you have. There are two types of "Green Bearings" being supplied by axle manufacturers. Your setup should look like Figure 2 (below left), not the Figure 1 configuration, otherwise this kit will not fit. Furthermore, review the wheel clearance diagram (Figure 3, below right) to verify that there is adequate clearance with the wheels you will be using with this installation.

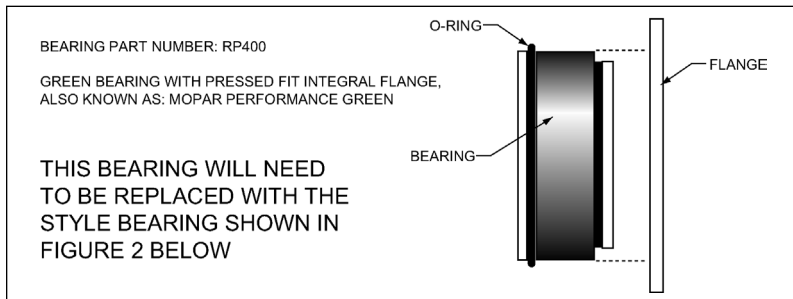

Figure 1. Press Fit Bearing Configuration



Figure 2. Loose Fit Bearing Configuration

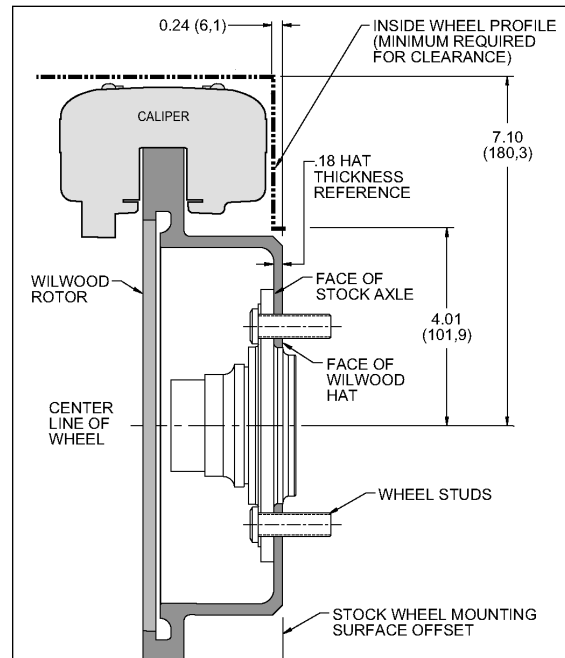

Figure 3. Wheel Clearance Diagram

## Exploded Assembly Diagram and Parts List

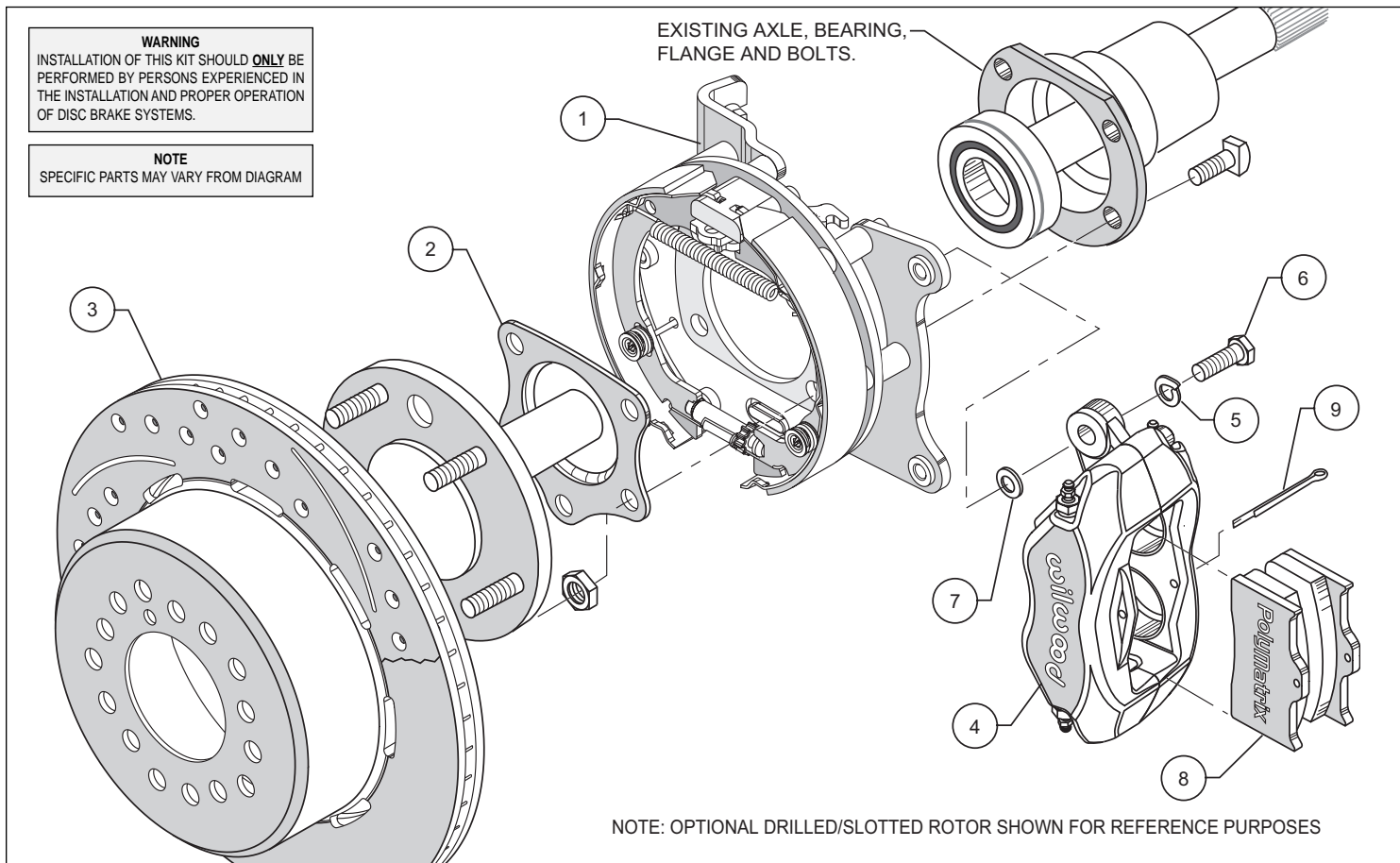

Figure 4. Typical Installation Configuration

## Parts List

ITEM NO.	PART NO.	DESCRIPTION	QTY
1	249-7116/17	Bracket Kit (pair, one each, left and right)	1
2	250-6488	Retainer, Bearing	2
3	160-6864	Rotor	2
3A	160-6968/69	Rotor, Drilled (pair, one each, left and right)	2
4	120-6806	Caliper, Forged Dynalite	2
4A	120-6791-P	Caliper, Forged Polished Dynalite	2
5	240-0140	Washer, Lock	4
6	230-0228	Bolt, 3/8-24 x 1.25 Long	4
7	240-1159	Shim	12
8	15T-5911	Pads, 7112T PolyMatrix "T" Compound	4
9	180-0055S	Cotter Pin	2

### NOTES:

Part Number 250-6488 is included with the bracket kit assembly 249-7116/17

Part Number 230-0204 Mounting Bolt Kit, includes P/N's 230-0228, 240-0140 & 240-1159

Item 3A is an optional item and is available in the (D) Drilled kits

Item 4A is an optional item and is available in the (P) Polished kits

## General Information and Assembly Instructions

Installation of this kit should **ONLY** be performed by persons experienced in the installation and proper operation of disc brake systems. Before assembling the Wilwood rear axle disc brake kit, double check the following items to ensure a trouble-free installation.

- Make sure this is the correct kit to fit the axle housing flange, not necessarily the rear end make. Many times after market manufacturers put a different make of axle housing flange on the stock rear end housing (see Figure 9). Example; Big Ford rear ends with Olds-Pontiac flanges, therefore, an Olds-Pontiac rear disc brake kit would be the correct kit to order. Also, shock clearance may be a problem. They may have to be modified and/or relocated to clear the Wilwood kit after final assembly.

- Inspect the package contents against the parts list to ensure that all components and hardware are included.

### •Verify The Following Measurements Before Assembly.

- Bearing outside diameter.
- That the bearing is the snap ring style bearing with removable flange (see Figure 2, preceding page).
- Axle housing flange mounting pattern to pattern in bracket.
- Stud pattern on axle flange to stud pattern in hat.
- Dimension from wheel side of axle flange to wheel side of axle housing flange (see Figure 9, lower right hand corner). This dimension is critical to ensure proper alignment of the rotor to the caliper, and should match offset given in the kit description.
- Verify that the wheel axle stud size is 0.50" diameter. The Wilwood rotors utilized in these kits are drilled for 0.50" diameter wheel studs.
- Maximum axle flange diameter must be no larger than 6.61" w/.050" x 45° chamfer (see Figure 5, right).

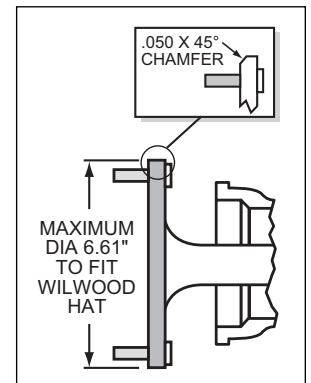

**Figure 5. Axle Flange Maximum Dimension**

### Assembly Instructions (numbers in parenthesis refer to the parts list/diagram on the preceding page):

- Disassemble the original equipment rear brakes:

Raise the rear wheels off the ground. Support the rear suspension by placing jack stands under the rear axle or vehicle frame. The vehicle's weight must be on jack stands. The vehicle must not be supported by a car jack or hoist.

Completely disassemble the stock brake system down to the bare axle. Dependent on the type of retainer supplied in the kit, the following steps must be performed.

A. **Full Circle Retainers** require the utilization of a qualified machine shop to press off the axle bearing and OEM retainer. Then have machine shop install new retainer (2), supplied with bracket kit with lip facing toward bearing and backing plate (or backing plate can be installed later by removal and replacement of bearing snap ring, reference Figures 4, 6 and 7 (we suggest that you install a new bearing at this time, not supplied with kit).

B. **"U" Retainers** require the removal of the OEM retainer by cutting or grinding a notch in the retainer to facilitate removal. Once OEM retainer is removed, install new retainer (2) supplied with bracket kit with the "U" opening facing up and the lip facing toward bearing, reference Figures 4, 6 and 7.

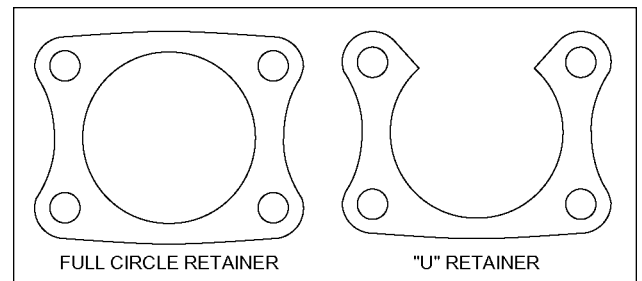

**Figure 6. Retainer Styles**

- Degrease and remove any dings and burrs on housing flange as well as axle flange which may interfere with brake assembly.

## General Information and Assembly Instructions (Continued)

- Slide the caliper mounting bracket kit assembly (1) onto the housing flange and then insert the axle assembly through the center hole of the caliper mounting bracket assembly (1). Align the bearing retainer (2) with the four holes inside the bracket assembly (1) and secure using the stock Original Equipment Manufacturer (OEM) bolts and nuts. Stock OEM hex nuts that retain the caliper mounting bracket assembly (1) and retainer (2) should be on the wheel side of the bracket. Apply red *Loctite*® 271 to the stock OEM bolt threads and torque to OEM specifications. Make sure the heads of the caliper mounting bracket assembly (1) insert nuts are **FACING OUTWARD TOWARDS THE WHEEL**.

- Align the correct hole pattern in the rotor (3) with the stud pattern on the axle flange. **NOTE:** Some OEM and after market axles come with stud sizes larger than 0.50" diameter. Verify stud size and have a qualified machine shop drill the bolt circle of the rotor to the correct stud size, if necessary. Slide the rotor (3) over the wheel studs covering the mounting bracket assembly (1) and against the axle flange face.

- WITH THE BLEED SCREWS POINTING UP**, mount the caliper (4) over the rotor (3) and onto the caliper mounting bracket (1) using lock washers (5) and mounting bolts (6). View the rotor through the top opening of the caliper. The rotor should be aligned in the center of the caliper. If not, adjust the caliper by using 0.032 inch shims (7) by placing them between the caliper mounting bracket (1) and the caliper (7). Apply red *Loctite*® 271 to the mounting bolt threads (6), torque to 30 ft-lb. Safety wire the caliper mounting bolts (6), see Figure 8.

- Position the Wilwood disc brake pads (8) into the caliper (4) and fasten with cotter pin (9). Steel backing plate side of brake pad should face the caliper pistons.

- NOTE:** Clevis and cable kits which attach to the parking brake assembly are not included in the Wilwood parking brake kit. Because of the numerous variations it is impossible to supply a generic style that would be applicable to all applications. Lokar Performance Products and their distributors carry a complete line of cable kits and accessories that will fit this system. They can be reached at 865 / 966-2269.

- Before final installation of the wheel, install a couple of lug nuts and adjust the parking brake shoes outward (using a drum shoe adjustment tool available at your local auto parts store) while spinning the rotor/hat (3) until a slight drag is felt again the hat/drum.

- NOTE:** The caliper inlet hole has a 1/8-27 NPT thread. A steel fitting, straight or a 90° elbow should be installed in the caliper. We recommend using stainless steel braided flex line. **THE OEM RUBBER HOSES SHOULD NOT BE USED.**

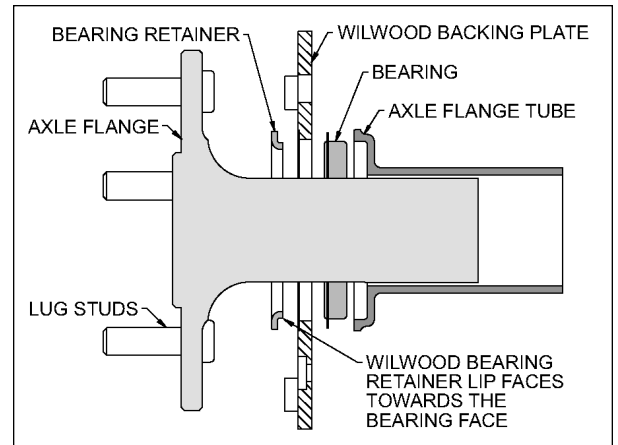

Figure 7. Retainer / Axle Diagram

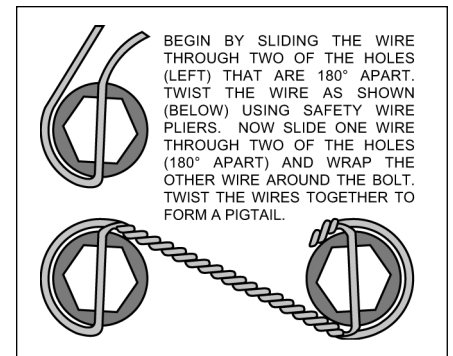

Figure 8. Safety Wire Diagram

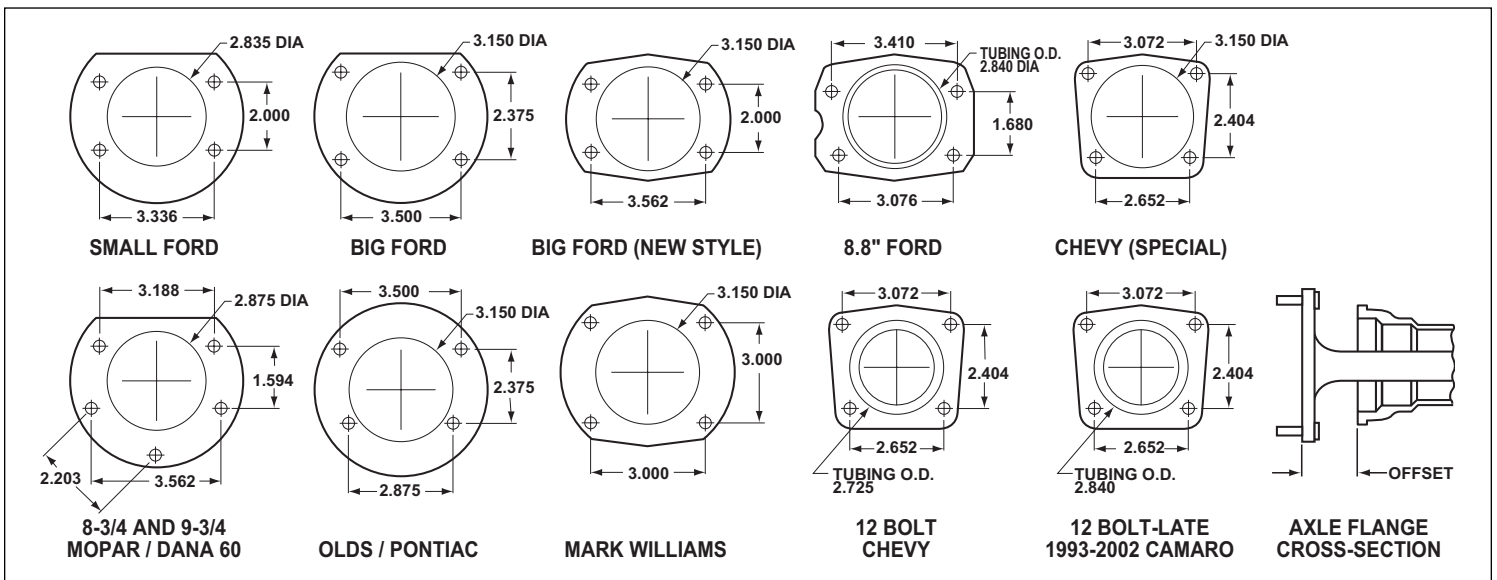

Figure 9. Rear Housing Flange Chart and Axle Flange / Offset Cross-Section

## Additional Information and Recommendations

- With the Wilwood disc brake system completely installed, use either of the two methods listed to balance the brake bias front to rear.
  - The Most Efficient Method:**  
A Wilwood brake pedal/balance bar assembly (either floor or swing mount) and two single master cylinders (either two 7/8 inch or two 1 inch) mounted side by side. Dialing the balance bar left or right transfers the pressure from front to rear, or rear to front and allows the smallest of pressure adjustments to be made without any loss to the overall brake system line pressure.
  - The More Popular Method:**  
An OEM 1-1/16 inch bore dual outlet master cylinder with a Wilwood adjustable proportioning valve plumbed into either the front or rear brake line. **NOTE:** A proportioning valve is an in-line pressure reducing device. Output pressure is reduced proportionally to input pressure. Net result is that the line pressure is reduced, forcing the remaining brakes to do more of the work.
- Fill and bleed the new system with Wilwood Hi-Temp° 570 grade fluid or higher. For severe braking or sustained high heat operation, use Wilwood EXP 600 Plus Racing Brake Fluid. Used fluid must be completely flushed from the system to prevent contamination. **NOTE:** Silicone DOT 5 brake fluid is **NOT** recommended.
- To properly bleed the brake system, begin with the caliper farthest from the master cylinder. Bleed the outboard bleed screw first, then the inboard. Repeat the procedure until all calipers in the system are bled, ending with the caliper closest to the master cylinder. **NOTE:** When using a new master cylinder, it is important to bench bleed the master cylinder first.
- If the master cylinder is mounted lower than the disc brake calipers, some fluid flowback to the master cylinder reservoir may occur, creating a vacuum effect that retracts the caliper pistons into the housing. This will cause the pedal to go to the floor on the first stroke until it has "pumped up" and moved all the pistons out against the pad again. A Wilwood in-line two pound residual pressure valve, installed near the master cylinder will stop the fluid flowback and keep the pedal firm and responsive.
- Test the brake pedal. It should be firm, not spongy and stop at least 1 inch from the floor under heavy load.
  - If the brake pedal is spongy, bleed the system again.
  - If the brake pedal is initially firm, but then sinks to the floor, check the system for fluid leaks. Correct the leaks (if applicable) and then bleed the system again.
  - If the brake pedal goes to the floor and continued bleeding of the system does not correct the problem, a master cylinder with increased capacity (larger bore diameter) will be required. Wilwood offers various lightweight master cylinders with large fluid displacement capacities.
- NOTE:** With the installation of after market disc brakes, the wheel track may change depending on the application. Check your wheel offset before final assembly.
- If after following the instructions, you still have difficulty in assembling or bleeding your Wilwood disc brakes, consult your local chassis builder, or retailer where the kit was purchased for further assistance.

### **PAD BEDDING PROCEDURE:**

- Pump brakes at low speed to assure proper operation. On the race track, or other safe location, make a series of hard stops until some brake fade is experienced. Allow brakes to cool while driving at moderate speed to avoid use of the brakes. This process will properly burnish the brake pads, offering maximum performance.

### Associated Components

<u>PART NO.</u>	<u>DESCRIPTION</u>
260-1874	Wilwood Residual Pressure Valve (2 lb for disc brakes)
260-1876	Wilwood Residual Pressure Valve (10 lb for drum brakes)
260-2220	Wilwood Proportioning Valve
290-0632	Wilwood Racing Brake Fluid (Hi-Temp° 570) (12 oz)
290-6209	Wilwood Racing Brake Fluid (EXP 600 Plus) (16.9 oz)
340-1285	Wilwood Floor Mount Brake Pedal (with balance bar)
340-1287	Wilwood Swing Mount Brake Pedal (with balance bar)
260-6764	Wilwood 3/4 inch High Volume Aluminum Master Cylinder
260-6765	Wilwood 7/8 inch High Volume Aluminum Master Cylinder
260-6766	Wilwood 1 inch High Volume Aluminum Master Cylinder
260-4893	1-1/16 inch Tandem Master Cylinder (aluminum housing)
250-2406	Mounting Bracket Kit (tandem master cylinder)
350-2038	1971 - 1973 Pinto Rack and Pinion (new, not rebuilt)
270-2016	Quick Release Steering Hub (3/4 inch shaft)
270-2017	Quick Release Steering Hub (5/8 inch shaft)
220-0149	Fitting, Straight (1/8-27 NPT to -4)
220-0842	Fitting, 90° Elbow (1/8-27 NPT to -4)

(Consult the Wilwood Catalog for a complete parts list)

### Bolt Torque Specifications

<u>BOLT SIZE</u>	<u>TORQUE</u>
1/4-20	85 in-lb
1/4-28	103 in-lb
5/16-18	180 in-lb
5/16-24	198 in-lb
3/8-16	22 ft-lb
3/8-24	30 ft-lb
7/16-14	42 ft-lb
7/16-20	47 ft-lb
1/2-13	65 ft-lb
1/2-20	77 ft-lb
9/16-12	95 ft-lb
9/16-18	105 ft-lb
5/8-11	110 ft-lb
5/8-18	120 ft-lb

**NOTE:** This bolt torque specification list is for use with specific grades of bolts as supplied in the particular Wilwood kit and is not intended as a guide for any other application.