

ASSEMBLY INSTRUCTIONS
FOR
SUPERLITE 6 BIG BRAKE FRONT HUB KIT
WITH 12.90" DIAMETER VENTED ROTOR

1971 - 1980 PINTO • 1974 - 1978 MUSTANG II
(FIVE LUG CONFIGURATION ONLY)*

PART NUMBER GROUP

140-7018-B

**DISC BRAKES SHOULD ONLY BE INSTALLED BY SOMEONE
EXPERIENCED AND COMPETENT IN THE INSTALLATION
AND MAINTENANCE OF DISC BRAKES**

READ ALL WARNINGS

WARNING

IT IS THE RESPONSIBILITY OF THE PERSON INSTALLING ANY BRAKE COMPONENT OR KIT TO DETERMINE THE SUITABILITY OF THE COMPONENT OR KIT FOR THAT PARTICULAR APPLICATION. IF YOU ARE NOT SURE HOW TO SAFELY USE THIS BRAKE COMPONENT OR KIT, YOU SHOULD NOT INSTALL OR USE IT. DO NOT ASSUME ANYTHING. IMPROPERLY INSTALLED OR MAINTAINED BRAKES ARE DANGEROUS. IF YOU ARE NOT SURE, GET HELP OR RETURN THE PRODUCT. YOU MAY OBTAIN ADDITIONAL INFORMATION AND TECHNICAL SUPPORT BY CALLING WILWOOD AT (805) 388-1188, OR VISIT OUR WEB SITE AT WWW.WILWOOD.COM. USE OF WILWOOD TECHNICAL SUPPORT DOES NOT GUARANTEE PROPER INSTALLATION. YOU, OR THE PERSON WHO DOES THE INSTALLATION MUST KNOW HOW TO PROPERLY USE THIS PRODUCT. IT IS NOT POSSIBLE OVER THE PHONE TO UNDERSTAND OR FORESEE ALL THE ISSUES THAT MIGHT ARISE IN YOUR INSTALLATION.

RACING EQUIPMENT AND BRAKES MUST BE MAINTAINED AND SHOULD BE CHECKED REGULARLY FOR FATIGUE, DAMAGE, AND WEAR.



WARNING

DO NOT OPERATE ANY VEHICLE ON UNTESTED BRAKES!
SEE MINIMUM TEST PROCEDURE WITHIN

ALWAYS UTILIZE SAFETY RESTRAINT SYSTEMS AND ALL OTHER AVAILABLE SAFETY EQUIPMENT WHILE OPERATING THE VEHICLE.

IMPORTANT • READ THE DISCLAIMER OF WARRANTY INCLUDED IN THE KIT.

NOTE: Some cleaners may stain or remove the finish on brake system components. Test the cleaner on a hidden portion of the component before general use.

Important Notice - Read This First

Before any tear-down or disassembly begins, review the following information:

- Review the wheel clearance diagram (figure 2, page 3) to verify that there is adequate clearance with the wheels you will be using with the installation.
- Front brake kits do not include flex lines. OEM brake lines will not adapt to Wilwood calipers. Check the assembly instructions, or associated components section for brake line recommendations before assembly. In addition, Wilwood offers an extensive listing of brake lines and fitting on our web site: www.wilwood.com.
- Due to OEM production differences and other variations from vehicle to vehicle, the fastener hardware and other components in this kit may not be suitable for a specific application or vehicle.
- It is the responsibility of the purchaser and installer of this kit to verify suitability / fitment of all components and ensure all fasteners and hardware achieve complete and proper engagement. Improper or inadequate engagement can lead to component failure.

Exploded Assembly Diagram

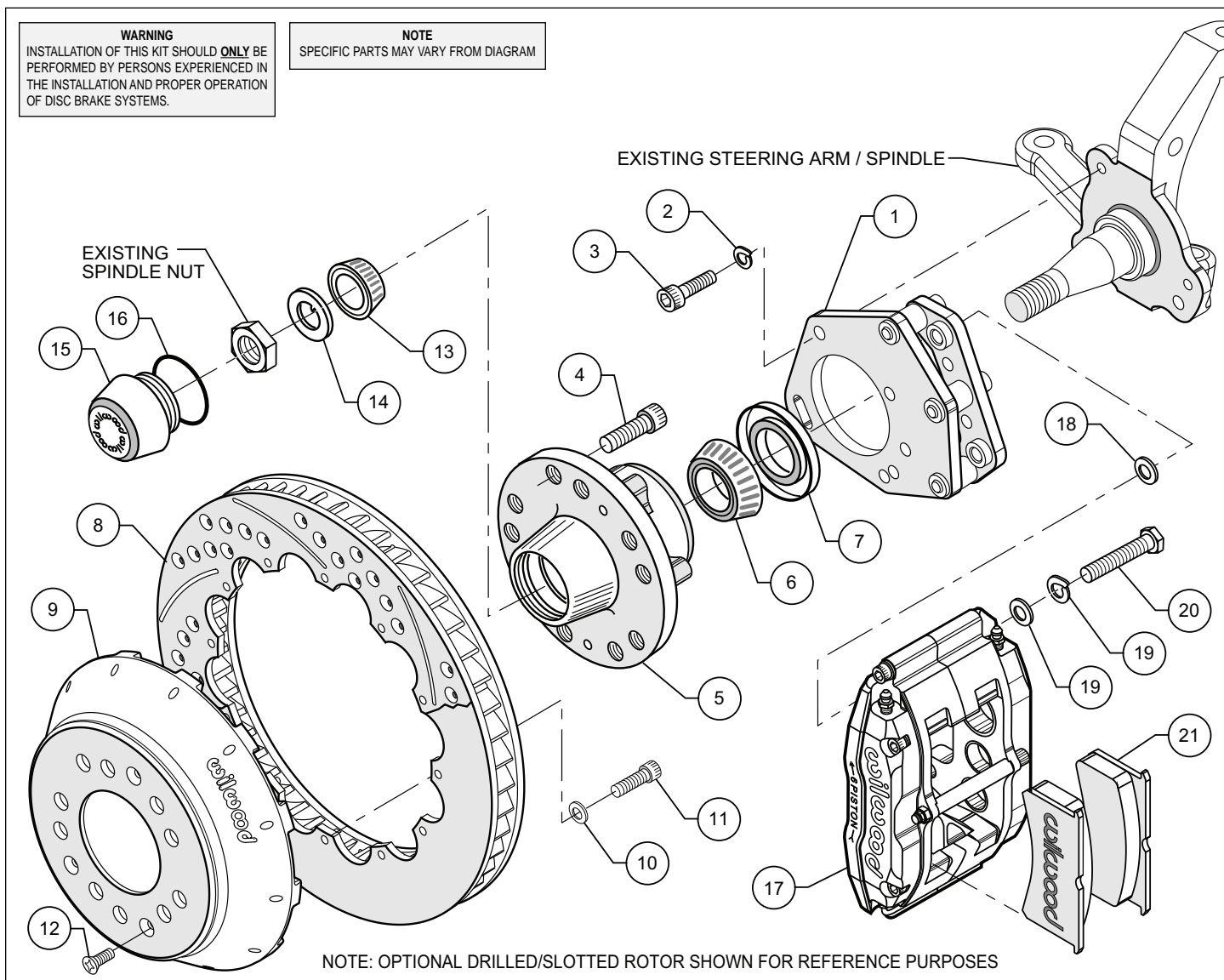

Figure 1. Typical Installation Configuration

Parts List

ITEM NO.	PART NO.	DESCRIPTION	QTY
1	249-6942/43	Brackets, Caliper Mounting (pair, one each, left and right)	1
2	240-0140	Washer, Lock 3/8 inch	6
3	230-1840	Bolt, 3/8-16 x 1.00 Long, SHCS	6
4	230-6959	Stud, 1/2-20 x 2.00 Long, SHCS	10
5	270-6989	Hub Assembly	2
6	370-0884	Cone, Inner Bearing	2
7	380-0885	Seal, Grease	2
8	160-6833/34	Rotor, 1.10" Thick x 12.90" Dia, 12 x 8.75" Bolt Circle	2
8A	160-6835/36	Rotor, Drilled and Slotted	2
9	170-6994	Hat	2
10	240-2509	Washer, 1/2 inch	24
11	230-6737	Bolt, 1/4-20 x 1.00 Long, 12 PT CS	24
12	230-7029	Bolt, 1/4-20 x 0.50 Long, FHCS	6
13	370-0882	Cone, Outer Bearing	2
14	240-2444	Washer, 7/8 Spindle	2
15	270-2158	Cap, Dust	2
16	211-1674	O-ring	2
17	120-7228/29-RS	Caliper, Billet Superlite 6, (one each, left and right)	2
17A	120-7259/60-RSP	Caliper, Polished Billet Superlite 6 (one each, left and right)	2
18	240-1848	Washer, Shim 0.032 Inch Thick	16
19	240-0139	Washer, Lock 7/16 Inch	4
20	230-6381	Bolt, 7/16-20 x 1.75 Long, Hex Head	4
21	150-8855k	Pad, BP-10 Compound, Axle Set	1

NOTES: Part Number 230-4572 Bolt Kit, rotor to hat, includes part numbers 230-6737 and 240-2509
 Part Number 230-7030 Bolt Kit, bracket to spindle, includes part numbers 230-1840 and 240-0140
 Part Number 230-7031 Bolt Kit, caliper to bracket, includes part numbers 230-6381 240-0139 and 240-1848
 Part Number 230-7032 Bolt Kit, hub to hat, includes part number 230-7029
 Item 8A is an optional item and is included in the "-D" Kits, add "-D" to end of part number when ordering
 Item 17A is an optional item and is included in the "-P" kits, add "-P" to end of part number when ordering

General Information and Disassembly Instructions

Installation of this kit should **ONLY** be performed by persons experienced in the installation and proper operation of disc brake systems. Before assembling the Wilwood front disc brake kit, double check the following items to ensure a trouble-free installation.

- Make sure this is the correct kit to match the exact make and model year of the vehicles spindle (i.e., hubs for a 1975 Mustang spindle may not fit a 1982 Mustang spindle).
- Verify the hub stud pattern in this kit (5 x 4.50 or 5 x 4.75) matches the stud pattern of the vehicles wheels.
- Inspect the package contents against the parts list to ensure that all components and hardware are included.

Disassembly Instructions:

- Disassemble the original equipment front brakes:
 Raise the front wheels off the ground. Support the front suspension by placing jack stands under the lower control arms. The lower control arms **MUST** be supported. The vehicle's weight must be on jack stands and not supported by a car jack or hoist.

Disconnect the brake hoses from the original equipment caliper. Unbolt and remove the original caliper from the original caliper bracket.

Remove the center cap, cotter pin, nut lock wheel bearing nut and wheel bearing washer. Save the wheel bearing nut and nut locking device. Remove the brake drum or rotor and hub assembly, including the wheel bearings.

Remove the original caliper bracket bolts and caliper bracket. Remove the dust shield retaining bolts and the dust shield.

- Thoroughly clean the spindles.

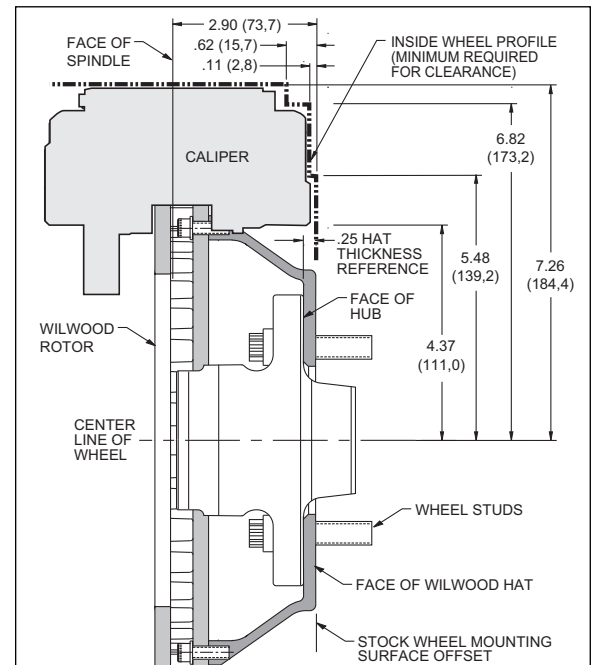

Figure 2. Wheel Clearance Diagram

Assembly Instructions

Assembly Instructions (numbers in parenthesis refer to the part list/diagram on the preceding page): **CAUTION:** All mounting bolts must fully engage insert nuts. Be sure to check that all bolts are either flush or protruding through flanged side of insert nut after shimming.

- Position the caliper mounting bracket (1) on the spindle with the offset plate facing towards the center of the vehicle. **NOTE:** Be sure the heads of the caliper bracket (1) insert nuts are facing outward toward the wheel. Place one lock washer (2) on each of the three caliper bracket bolts (3). Mount bracket to the dust plate face of the spindle and align the three 3/8-16 holes in the spindle with the corresponding holes in the bracket (1). Apply red *Loctite*® 271 to all three bolt threads (3) and install. Torque bolts (3) to 35 ft-lb.
- Install wheel studs (4) into the hub (5). Torque to 77 ft-lb. **NOTE:** There are two lug patterns of five holes each in the hub (5 x 4.50 and 5 x 4.75). Make sure of the correct hole pattern for the wheel application before installing the studs into the hub.
- Pack the large inner bearing cone (6) with high temperature disc brake bearing grease (available from your local auto parts store) and install into the backside of the hub (5).
- Install the grease seal (7) into the backside of the hub (5).
- Pack the small outer bearing cone (13) with high temperature disc brake bearing grease and install into front side of the hub (5). Slide the hub assembly (5, 6, 7 and 13) onto the spindle. Secure using spindle washer (14), stock adjusting nut, and nut locking device. Adjust wheel bearing pre-load per Original Equipment Manufacturer (OEM) specifications.
- Install the o-ring (16) and the dust cap (15) into the hub (5). **NOTE:** O-ring (16) friction will not allow cap (15) to unscrew on its own.
- With the larger I.D. side of the rotor (8) facing away from the hat (9), bolt rotor (8) to hat (9) through the backside of the rotor using washers (10) and bolts (11). Torque bolts (11) to 85 in-lb. Safety wire bolts (11) using standard 0.032 inch diameter stainless steel safety wire as shown in Figure 3. Please refer to Wilwood's data sheet DS-386 (available at www.wilwood.org/ds386.pdf) for complete safety wire installation instructions.

- Slide the rotor/hat assembly over the studs (4) in the hub (5) taking care to align the small countersunk holes in the hat (9) with the small threaded holes in the hub (5). Install three flat head socket head screws (12) through the small holes in the hat (9) and torque to 85 in-lb.

- NOTE:** Please reference the caution statement at the beginning of the assembly instructions. With the bleed screws pointing up, mount the caliper (17) to the caliper mounting bracket (1) using two bolts (20), two lock washers (19) and two flat washers (18). Finger tighten the bolts (20). **NOTE:** Please be sure with differential bore calipers that the "large" piston is on the "exit" side of the rotor. View the rotor (8) through the top of the caliper (17). The rotor (8) should be centered in the caliper's top opening (17). If not, loosen the two bolts (20) and adjust the caliper (17) position by using 0.030 inch thick shim washers (18). The shim washers (18) should be placed between the caliper (17) and the caliper mounting bracket (1). Finger tighten bolts (20) and recheck caliper (17) alignment. Add as many shim washers (18) as necessary to achieve the correct alignment. Always use the same amount of shims on both the top and bottom caliper mounting bolts (20). Loosen the two bolts (20) and apply red *Loctite*® 271 to bolt threads (20) and torque to 47 ft-lb. Safety wire the two bolts (20) using wire manufactured for the purpose of securing nuts and bolts. **HINT:** If more than two shim washers (18) are needed per bolt (20), a small drop of red *Loctite*® 271 between the shim washers will help hold them together during assembly.

- Remove the caliper bridge spacer and bolt, then install the disc brake pads (21), then reinstall the caliper bridge spacer and bolt.
- Repeat entire procedure for the other wheel.

- NOTE:** OEM rubber brake hoses generally cannot be adapted to Wilwood calipers. The caliper inlet fitting is a 1/8-27 NPT. The preferred method is to use steel adapter fittings at the caliper, either straight, 45 or 90 degree and enough steel braided line to allow for full suspension travel and turning radius, lock to lock. **Carefully route lines to prevent contact with moving suspension, brake or wheel components.** Wilwood hose kits are designed for use in many different vehicle applications and it is the installer's responsibility to properly route and ensure adequate clearance and retention for brake hose components.

- Specified brake hose kits may not work with all Years, Makes and Models of vehicle that this brake kit is applicable to, due to possible OEM manufacturing changes during a production vehicle's life. It is the installer's responsibility to ensure that all fittings and hoses are the correct size and length, to ensure proper sealing and that they will not be subject to crimping, strain and abrasion from vibration or interference with suspension components, brake rotor or wheel.

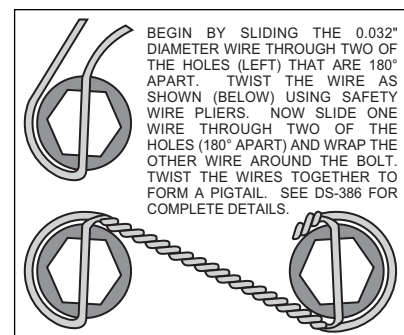

Figure 3. Safety Wire Diagram

Assembly Instructions (Continued)

- In absence of specific instructions for brake line routing, the installer must use his best professional judgment on correct routing and retention of lines to ensure safe operation. Test vehicle brake system per the 'minimum test' procedure stated within this document before driving. After road testing, inspect for leaks and interference. Initially after install and testing, perform frequent checks of the vehicle brake system and lines before driving, to confirm that there is no undue wear or interference not apparent from the initial test. Afterwards, perform periodic inspections for function, leaks and wear in a interval relative to the usage of vehicle.
- Bleed the brake system. Reference the general information and recommendations below for proper bleeding instructions.

Balancing the Brake Bias on 4 Wheel Disc Vehicles

•OE Style or Single Mount Race Pedal with Tandem Outlet Master Cylinder:

Front to rear caliper piston sizes, rotor diameters, and pad compounds must be initially configured to provide the correct range of vehicle bias when using a single bore / tandem outlet master cylinder. If excessive rear brake bias is experienced, an inline adjustable proportioning valve can be used to decrease the rear line pressure to help bring the vehicle into balance. If excessive front brake bias is experienced, first consideration should be given to increasing the rear brake bias to bring the vehicle into overall balance.

•Race Pedal with Dual Master Cylinders and Balance Bar:

Master cylinders must be sized to match the calipers and allow the pedal balance bar to operate near the center of its travel. If it is not possible to fine tune the bias within the adjustable range of the balance bar, then consideration must be given to changing a master cylinder bore size or some other aspect of the brake system to bring the car into balance. Larger bore master cylinders will generate less pressure while decreasing pedal travel. Smaller bores master cylinders will generate higher line pressures with an increase in pedal travel.

Additional Information and Recommendations

- Fill and bleed the new system with Wilwood Hi-Temp^o 570 grade fluid or higher. For severe braking or sustained high heat operation, use Wilwood EXP 600 Plus Racing Brake Fluid. Used fluid must be completely flushed from the system to prevent contamination.
NOTE: Silicone DOT 5 brake fluid is **NOT** recommended.
- To properly bleed the brake system, begin with the caliper farthest from the master cylinder. Bleed the outboard bleed screw first, then the inboard. Repeat the procedure until all calipers in the system are bled, ending with the caliper closest to the master cylinder.
NOTE: When using a new master cylinder, it is important to bench bleed the master cylinder first.
- If the master cylinder is mounted lower than the disc brake calipers, some fluid flowback to the master cylinder reservoir may occur, creating a vacuum effect that retracts the caliper pistons into the housing. This will cause the pedal to go to the floor on the first stroke until it has "pumped up" and moved all the pistons out against the pad again. A Wilwood in-line two pound residual pressure valve, installed near the master cylinder will stop the fluid flowback and keep the pedal firm and responsive.
- Test the brake pedal. It should be firm, not spongy and stop at least 1 inch from the floor under heavy load.
 - If the brake pedal is spongy, bleed the system again.
 - If the brake pedal is initially firm, but then sinks to the floor, check the system for fluid leaks. Correct the leaks (if applicable) and then bleed the system again.
 - If the brake pedal goes to the floor and continued bleeding of the system does not correct the problem, a master cylinder with increased capacity (larger bore diameter) will be required. Wilwood offers various lightweight master cylinders with large fluid displacement capacities.
- **NOTE:** With the installation of after market disc brakes, the wheel track may change depending on the application. Check your wheel offset before final assembly.
- On some models of disc brake spindles there are "ears" where the OEM calipers were mounted and these "ears" interfere with the assembly of the Wilwood disc brake kit. If it becomes necessary to remove these "ears", remove as little as possible being careful not to cut away any of the mounting holes that may be required to bolt on the caliper mounting bracket.
- If after following the instructions, you still have difficulty in assembling or bleeding your Wilwood disc brakes, consult your local chassis builder, or retailer where the kit was purchased for further assistance.

Brake Testing and Pad Bedding

WARNING • DO NOT DRIVE ON UNTESTED BRAKES BRAKES MUST BE TESTED AFTER INSTALLATION OR MAINTENANCE MINIMUM TEST PROCEDURE

- Make sure pedal is firm: Hold firm pressure on pedal for several minutes, it should remain in position without sinking. If pedal sinks toward floor, check system for fluid leaks. DO NOT drive vehicle if pedal does not stay firm or can be pushed to the floor with normal pressure.
- At very low speed (2-5 mph) apply brakes hard several times while turning steering from full left to full right, repeat several times. Remove the wheels and check that components are not touching, rubbing, or leaking.
- Carefully examine all brake components, brake lines, and fittings for leaks and interference.
- Make sure there is no interference with wheels or suspension components.
- Drive vehicle at low speed (15-20 mph) making moderate and hard stops. Brakes should feel normal and positive. Again check for leaks and interference.
- Always test vehicle in a safe place where there is no danger to (or from) other people or vehicles.
- Always wear seat belts and make use of all safety equipment.

PAD BEDDING PROCEDURE:

- Pump brakes at low speed to assure proper operation. On the race track, or other safe location, make a series of hard stops until some brake fade is experienced. Allow brakes to cool while driving at moderate speed to avoid use of the brakes. This process will properly burnish the brake pads, offering maximum performance.

Associated Components

PART NO.	DESCRIPTION
260-1874	Wilwood Residual Pressure Valve (2 lb for disc brakes)
260-1876	Wilwood Residual Pressure Valve (10 lb for drum brakes)
260-8419	Wilwood Proportioning Valve
290-0632	Wilwood Racing Brake Fluid (Hi-Temp° 570) (12 oz)
290-6209	Wilwood Racing Brake Fluid (EXP 600 Plus) (16.9 oz)
340-1285	Wilwood Floor Mount Brake Pedal (with balance bar)
340-1287	Wilwood Swing Mount Brake Pedal (with balance bar)
260-6764	Wilwood 3/4 inch High Volume Aluminum Master Cylinder
260-6765	Wilwood 7/8 inch High Volume Aluminum Master Cylinder
260-6766	Wilwood 1 inch High Volume Aluminum Master Cylinder
260-4893	1-1/16 inch Tandem Master Cylinder (aluminum housing)
250-2406	Mounting Bracket Kit (tandem master cylinder)
260-8555	Wilwood 1 inch Aluminum Tandem Chamber Master Cylinder
260-8556	Wilwood 1-1/8 inch Aluminum Tandem Chamber Master Cylinder
350-2038	1971 - 1973 Pinto Rack and Pinion (new, not rebuilt)
270-2016	Quick Release Steering Hub (3/4 inch shaft)
270-2017	Quick Release Steering Hub (5/8 inch shaft)
220-7056	Flexline Kit, Universal, 14 Inch, Domestic
220-7699	Flexline Kit, Universal, 16 Inch, Domestic
220-8307	Flexline Kit, Universal, 18 Inch, Domestic

Bolt Torque Specifications

BOLT SIZE	TORQUE
1/4-20	85 in-lb
1/4-28	103 in-lb
5/16-18	180 in-lb
5/16-24	198 in-lb
3/8-16	22 ft-lb
3/8-24	30 ft-lb
7/16-14	42 ft-lb
7/16-20	47 ft-lb
1/2-13	65 ft-lb
1/2-20	77 ft-lb
9/16-12	95 ft-lb
9/16-18	105 ft-lb
5/8-11	110 ft-lb
5/8-18	120 ft-lb

NOTE: This bolt torque specification list is for use with specific grades of bolts as supplied in the particular Wilwood kit and is not intended as a guide for any other application.